



## Contents

1	General Information .....	4
1.1	Information about these operating instructions.....	4
1.2	Limitation of liability .....	4
1.3	Copyright .....	5
1.4	Replacement parts .....	5
1.5	Material defects .....	5
1.6	Technical support .....	5
2	Safety Information .....	6
2.1	Explanation of symbols.....	6
2.2	Personnel requirements .....	7
2.3	Personal protective equipment .....	8
2.4	Intended use.....	9
2.5	5 Safety Rules for working on electrical systems .....	9
2.6	Special dangers .....	9
3	Technical Data .....	15
3.1	Electrical .....	15
3.2	Mechanical .....	15
3.3	Operating conditions.....	17
4	Description and Functional Principle.....	18
4.1	Brief description .....	18
4.2	Description of assemblies.....	19
5	Transport, Packaging and Storage .....	23
5.1	Transport .....	23
5.2	Storage of packaged parts .....	23
6	Installation .....	25
6.1	Safety .....	25
6.2	Procedure .....	27
7	Commissioning .....	38
8	Operation .....	40

# Operating Instructions



## Conductor Rail System ChargeLine 0865

---

8.1	Safety .....	40
9	Maintenance and Service .....	41
9.1	Safety .....	41
9.2	Tools and materials .....	42
9.3	Cleaning .....	42
9.4	Maintenance plan .....	42
10	Troubleshooting Table .....	45
11	Disassembly and Disposal .....	47
11.1	Safety .....	47
11.2	Disassembly .....	47
11.3	Disposal .....	49
12	Additional Documents .....	50
12.1	Declaration of Conformity .....	50
12.2	Replacement parts list .....	50
12.3	Applicable documents .....	50
13	Index .....	51

## 1 General Information

---

### 1.1 Information about these operating instructions

The information provided in this document is designed to enable the equipment to be used safely and efficiently.

This document is a component of the system and must be kept accessible to personnel and in its immediate vicinity. Prior to commencing any work, personnel must have carefully read through and understood these operating instructions. The basic prerequisite for safe work is compliance with all safety information and operating guidelines in this document.

Local accident protection regulations and general safety guidelines for the area of use of the equipment also apply.

The illustrations in this document are provided for basic understanding and may deviate from the actual implementation of the conductor rail system.

In addition to this document, the instructions for the installed components in the appendix apply.

### 1.2 Limitation of liability

All existing standards and regulations, the latest technological standards, as well as our long years of know-how and experience, have been taken into account when formulating the information and notices in this document.

The manufacturer is in no way liable for damages resulting from:

- Failure to comply with the operating instructions
- Improper use
- Use by untrained personnel
- Unauthorized modifications
- Technical modifications
- Use of unauthorized replacement parts or accessories

The actual scope of delivery may differ from the explanations and descriptions provided here if the model in question is a special one, if additional equipment has been ordered or due to recent technical modifications.

The obligations agreed upon in the Delivery Agreement and our General Terms and Conditions of Business apply, as do the delivery conditions of the manufacturer and the legal regulations applicable at the time the contract was concluded.

All products are subject to technical modifications and the many years of technical expertise and experiences within the context of improvement of function and further development.

### 1.3 Copyright

These operating instructions are protected by copyright and exclusively intended for internal use by the customer.

Provision of the operating instructions to third parties, reproductions in any form – even in part – as well as the reuse and/or disclosure of their content are not permitted without the written approval of the manufacturer, except for the customer's internal use.

Breach or infringement will result in liability for damages. Our right to further claims remains unaffected.

### 1.4 Replacement parts



**WARNING!**

#### **Safety risk due to incorrect replacement parts!**

Incorrect or faulty replacement parts can impair safety and result in damage, malfunctions or complete failure.

→ Always use original replacement parts from the manufacturer!

Replacement parts must be purchased via authorized dealers or directly from the manufacturer.

See Section 13 for the contact details for ordering replacement parts.

### 1.5 Material defects

The terms governing material defects can be found in the General Terms and Conditions of Business.

### 1.6 Technical support

Our Customer Support staff is available for technical support.

Replacement parts ordering: See Section 13 for contact details.

We are also always interested in new information, experiences and feedback from the field that can help us improve our products.

## 2 Safety Information

---

### 2.1 Explanation of symbols

Safety and hazard information is identified in these operating instructions using symbols. Safety and hazard information is introduced by signal words that indicate the degree of the hazard. Always observe safety and hazard information and work carefully to avoid accidents, bodily injury and material damage!



**DANGER!**

... indicates an immediately hazardous situation, which if not avoided, may result in death or serious injury.



**DANGER!**

... indicates an immediately hazardous situation due to electrical current, which if not avoided, may result in death or serious injury.



**WARNING!**

... indicates a potentially hazardous situation, which if not avoided, may result in death or serious injury.



**WARNING!**

... indicates a potentially hazardous situation from electrical current, which if not avoided, may result in death or serious injury.



**CAUTION!**

... indicates a potentially hazardous situation that, if not avoided, may result in moderate or minor injury and material damage.



**Tips and recommendations:**

... refers to useful tips and recommendations as well as information for efficient and trouble-free operation.



**ATTENTION!**

... indicates actions that will help avoid material damage.

## 2.2 Personnel requirements

### 2.2.1 Qualifications



#### **WARNING!**

**Inadequately trained persons are at risk of injury!**

Improper use can result in serious injury to persons and material damage.

→ All activities may only be conducted by personnel who are qualified for the respective activity!

The following qualifications for the various levels of activities are indicated in these operating instructions:

#### ■ **Trained personnel/operators**

have been instructed in a training session by the operator with respect to the tasks assigned to them and the potential dangers arising from improper actions.

#### ■ **Specialist personnel**

consists of persons capable of performing assigned tasks and independently identifying dangers and avoiding potential hazards based on their specialist training, knowledge and experience as well as their understanding of the applicable standards and regulations.

Personnel are considered qualified if they have successfully concluded training, e.g. as electricians, master electricians, electrical engineers, or electrical technicians. Personnel are also considered qualified if they have been correspondingly employed for several years, have been educated in theory and practice during that time, and whose electrical knowledge and skills have been tested.

The operator of the electrical system must document that the corresponding certification or other documentation of qualification are present or have been demonstrated.

### 2.2.2 Unauthorized persons



#### **WARNING!**

**Danger due to unauthorized persons!**

Unauthorized persons who do not meet the requirements described here are not acquainted with the dangers in the work area.

→ Keep unauthorized persons away from the work area.

→ In case of doubt, address the persons and direct them away from the work area.

→ Stop working as long as unauthorized persons are in the work area.

## 2.3 Personal protective equipment

### Always wear

For all work, always wear:



#### Protective clothing

Primarily for protection against ensnarement by moving machine parts. Work clothing must be close fitting with a low resistance to tearing; it must have close-fitting sleeves and no protruding parts.



#### Protective footwear

For protection against heavy falling parts and slipping on slippery floors.

### To be worn for special work

**Specific protective equipment is required when conducting special work. Separate reference to this is made in the individual sections.**



#### Protective gloves

For the protection of hands against friction, scrapes, puncture or deeper wounds, as well as against contact with hot surfaces.



#### Protective headgear

For protection against falling or flying parts and materials.



#### Protective eyewear

For eye protection against harmful influences such as strong light, chemicals, dust, splinters or weather effects.



#### Breathing mask (FFP-3 – according to country-specific requirements)

For protection against materials, particles, and organisms. In this case: protection from dust caused by the wear of sliding contacts and insulation profile of the conductor rail.



## 2.4 Intended use

The product is exclusively designed and built for the intended use described herein.

Claims of any kind due to damages from unintended use are excluded.

The operator bears sole liability for all damage that results from unintended use.

### Intended use

The Conductor Rail System ChargeLine 0835 is an electric power supply system for track-guided mobile consumers operated in indoor spaces in warehouse areas not accessible to the public.

One of its typical applications is, e.g. to supply power to shuttles inside a warehouse with horizontal storage racks.

### Compliance with these technical conditions is mandatory for the installation:

- The permissible max. travel speed of the consumer is 400 m/min (straight lines), 120 m/min (pickup guide entry).
- Insertion from the side and laterally are both possible with a horizontal and floor-to-ceiling installation.
- The conductor rail system must be exclusively fitted and operated using copper materials.
- Max. permissible system length for standard installation: 50 m; max. 150 m when considering expansion.
- For dry indoor applications.

### Electrical-technical operating conditions

- The electrical system must be protected in accordance with local regulations and guidelines.

## 2.5 5 Safety Rules for working on electrical systems

### Requirements:



- Work on electrical systems must only be carried out when they are disconnected from the power supply. The **5 Safety Rules** must always be observed before starting work (see DIN VDE 0150-100:2009-10/EN 50110-1:2004-11).
  1. Disconnect the system from power at the main switch.
  2. Secure the main switch against being turned back on.
  3. Verify disconnection from power by measuring.
  4. Ground and short-circuit parts of the system on which work will be conducted.
  5. Cover or block off adjacent energized parts.
- Only electricians or personnel trained in electrical work may disconnect power or approve reconnection of power after the work is carried out in the disconnected state!

## 2.6 Special dangers

The following section lists residual risks determined on the basis of a risk assessment. Follow the safety information and the warnings in other sections in these operating instructions in order to reduce health hazards and avoid dangerous situations.

#### 2.6.1 Electrical hazards and sources of danger

##### Requirements:



**DANGER!**

##### **Risk of death due to electric shock!**

Contact with energized components can lead to death or severe injury due to electric shock. There is also a risk of injury from shock reactions, falling or being thrown across the room as a result of an electric shock.



**DANGER!**

##### **Risk of injury from falling or being thrown across the room after an electric shock!**

Work on the following components is dangerous:

- Main power supply
- Energized parts:
  - Line feed
  - Cables
  - Connections
  - Conductor rail
  - Connector
  - Current collector
  - Equipment and connections inside switching cabinets
  - Control systems etc.
- Parts that have become energized due to a fault



**CAUTION!**

##### **Before working on these components!**

→ Switch off the **conductor rail system according to the 5 Safety Rules and secure it against being switched on again**. 5 Safety Rules, see Section 2.5



**CAUTION!**

##### **Before switching the system on!**

→ Each time before the equipment or system is started, measure the insulation resistance according to locally applicable technical standards, directives and legal regulations.

→ Carry out locally required electrical tests.



**CAUTION!**

##### **Maintain electrical safety!**

→ Regularly test and maintain electrical equipment.

→ If dangerous deficiencies are identified, take measures to correct the deficiencies without delay. Inform the system operator immediately.

→ If it is not possible to correct the dangerous deficiency, cordon off the area involved or switch the equipment off and secure it against being switched on again. Inform the system operator immediately.

→ Immediately secure loose cables and replace damaged cables.

→ Always replace blown fuses with fuses of the same rating.



**DANGER!**

#### **Fire hazard due to overload or sparking!**

Fire hazards occur due to overload of the cables, electrical arcs, short circuits, or the formation of sparks. Sparks can form in poorly serviced, contaminated conductor rails or if the installation does not comply with required tolerances.

- Always comply with permissible current values.
- Comply with tolerances during installation.
- Install electrical fuses according to specifications.
- Do not store easily ignited materials in the vicinity of conductor rails.
- Check, service and clean conductor rails regularly and in accordance with specifications. See Section 12.3

## 2.6.2 Mechanical hazards and sources of danger

Required protective equipment:



**DANGER!**

#### **Risk of injury through crushing and impacts!**

There is a risk of crushing of skin and limbs due to:

- Current collector (spring force) during installation, disassembly and maintenance.
- Falling conductor rail system components, if they have not been properly installed or if operated under unsuitable operating conditions (e.g., environment that contains solvents).
- Moving parts, when the system is in operation.

- Do not enter the danger zones of the system during operation.
- Only allow installation to be conducted by trained technicians.
- When working on the conductor rail system, wear protective footwear, protective gloves and protective headgear.
- When changing the sliding contacts, follow the separate instructions for this task. See Section 12.3
- Only install the conductor rail system where suitable operating conditions prevail. See Section 3.3.1

#### Required protective equipment:



**DANGER!**

#### **Risk of injury due to cutting and severing!**

The ends of the conductor bars can have sharp edges, particularly if they were cut to size at the installation site and have not been deburred.

- Wear protective gloves and protective footwear.
- Carefully deburr the insulation profile and conductor bars after sawing.
- During disassembly: Sawed through, disassembled conductor rails must be handled carefully and properly stored (container or transport box).
- Watch for sharp edges near the installation surface and avoid contact.

#### Required protective equipment:



**DANGER!**

#### **Risk of injury from falling conductor bars when transported incorrectly!**

When being transported on the installation site, there is a risk that the conductor bars may slide out of the insulation profiles if they are not held relatively vertical during transport. Considering the sharp facings, this can cause serious injury and even death if they fall from a great height.

- The conductor rails should be transported as close as possible to the installation site while still inside their packaging.
- The conductor rails must be transported to the installation site by two people and care must be taken that the conductor bars do not slide out of the insulation profiles.
- Do not transport the conductor rails in bundles with a crane.
- Wear protective headgear.

#### Required protective equipment:



**DANGER!**

#### **Risk of injury due to ensnarement!**

There is a risk of being ensnared by moving parts when the system is in operation. Moving parts include, e.g. the shuttle and the attached current collector.

- Do not enter the danger zones of the system during operation.
- **Before working on the conductor rail, switch off the conductor rail system according to the 5 Safety Rules and secure it against being switched back on.** For the 5 Safety Rules, see Section 2.5
- Wear closely fitting work clothing.

#### 2.6.3 Danger due to dust and vapors

Required protective equipment:



**DANGER!**

##### **Danger of sensitization, mucous membrane irritation and respiratory diseases due to dust!**

Dust from the sliding contact collects in the conductor rails and the guideway profile. This dust is very fine and is categorized as a health hazard. Frequent handling of the conductor rail system and/or not applying the requisite level of care when handling accumulated dust (e.g. cleaning the system with compressed air) can lead to sensitization. Persons who frequently spend longer periods in a heavily used system without protective equipment must reckon with the following **consequences**:

- Irritations of the mucous membranes
- Respiratory diseases
- Cancer

→ In workplaces with long-term exposure and frequently visited systems, take effective measures to protect employees from the dust.

→ Personal protective equipment must be worn during all work on the conductor rail system during which accumulated dust can be stirred up.

→ The following personal protective equipment must be worn during cleaning:

- Protective eyewear
- Protective dust mask, Class FFP3
- Protective gloves
- Disposable coveralls

→ Before starting work, clean the conductor rail in accordance with requirements. See Section 12.3

→ Protect the surroundings during cleaning work, e.g. by covering or removing warehouse goods and blocking access to those areas in which dust could fall down on persons.

→ **Do not blow out dust with compressed air**, but rather vacuum it away. The vacuum must be equipped with a Class H fine filter.

→ Do not eat or drink during work!

→ Do not smoke during work!



**DANGER!**

##### **Poisonous gases during fire!**

In case of fire in the facility, the plastic parts (PVC) of the conductor rail system will produce poisonous gases (HCL).

→ Evacuate the building immediately in the event of fire.

→ Notify the fire department in the case of fire.

#### 2.6.4 Dangers related to the operational environment

These characteristics of the conductor rail can cause danger if the conductor rail is installed in an operational environment with:

- Electrical power
- Sparking
- Dust due to abrasion
- Toxic gases during fire.

The **most important action** for protection from these dangers is only to install the conductor rail system in locations where **suitable operating conditions prevail**; see Section 3.3.1.

Required protective equipment:



**DANGER!**

#### **Danger of sensitization, mucous membrane irritation and respiratory diseases due to dust!**

Dust from the sliding contact collects in the conductor rails and the guideway profile. This dust is very fine and is categorized as a health hazard. Frequent handling of the conductor rail system and/or not applying the requisite level of care when handling accumulated dust (e.g. cleaning the system with compressed air) can lead to sensitization. Persons who frequently spend longer periods in a heavily used system without protective equipment must reckon with the following **consequences**:

- Irritations of the mucous membranes
- Respiratory diseases
- Cancer

→ In workplaces with long-term exposure and frequently visited systems, take effective measures to protect employees from the dust.

→ Personal protective equipment must be worn during all work on the conductor rail system during which accumulated dust can be stirred up.

→ The following personal protective equipment must be worn during cleaning:

- Protective eyewear
- Protective dust mask, Class FFP3
- Protective gloves
- Disposable coveralls

→ Before starting work, clean the conductor rail in accordance with requirements. See Section 12.3

→ Protect the surroundings during cleaning work, e.g. by covering or removing warehouse goods and blocking access to those areas in which dust could fall down on persons.

→ **Do not blow out dust with compressed air**, but rather vacuum it away. The vacuum must be equipped with a Class H fine filter.

→ Do not eat or drink during work!

→ Do not smoke during work!

## 3 Technical Data

### 3.1 Electrical

Rated current		100 A for complete 0865 units when using 2 line feeds 32 A for conductor rail systems from 0835 and 0865 or units connected by 0835 connectors. 34 A for 0865 Mobile Unit
Rated voltage	Variant 60 V Low voltage variant	AC ≤ 25V, DC ≤ 60V AC ≤ 230V, DC ≤ 400 V
Number of poles		2
Assignment		2 phases or 1 phase, PE
Cross-sections for connecting cables		2.5mm <sup>2</sup> and 6mm <sup>2</sup> double insulated 2.5mm <sup>2</sup> , 6mm <sup>2</sup> and 10mm <sup>2</sup> single insulated
Conductor material		Copper
Protection class		IP 21 for conductor rail components IP 00 for current collector

### 3.2 Mechanical

Max. travel speed		On straight lines 400 m/min At pickup guide entry 120 m/min
Direction of travel		Forward and backward (reversing)
Gap between poles		14 mm

#### 3.2.1 Length

Max. length of the installed conductor rail		Maximum length without additional expansion joints 50 m and variable
Conductor rail segment		Segment length variable Standard length: 500 mm 750 mm 1000 mm
Min. permissible conductor bar length		250 mm
Hanger spacing		800 mm

#### 3.2.2 Installation orientation



**WARNING!**

**Only install the conductor rail horizontally and straight (see Section 3.2.3)!**

## Conductor Rail System

### ChargeLine 0865



A current collector insertion from above means a great deal of grime and soiling, which leads to an increased cleaning effort.

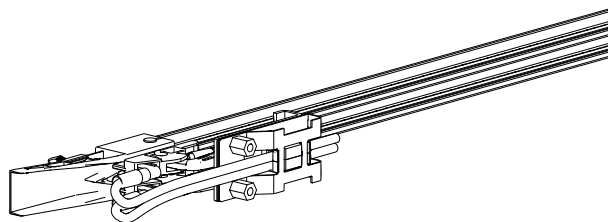

Fig. 1: Lateral insertion of current collector

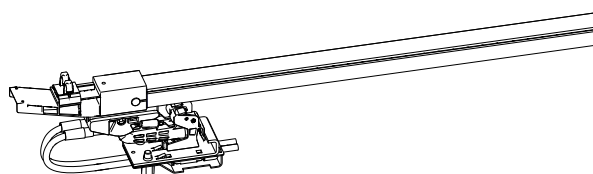

Fig. 2: Current collector inserted from below

### 3.2.3 Tolerances

The conductor rail must be installed within the following tolerances. Conductix-Wampfler does not guarantee the trouble-free function of the conductor rails if these tolerances are not observed. In such a case, Conductix-Wampfler does also not accept any liability for any problems that may arise if the conductor rail system does not function trouble-free.

Conductor rails/pickup guide	$\pm 2$ mm in X-direction, $\pm 3$ mm in Y-direction (see Fig. 3)
Gap at the connector between 2 conductor bars	2.5 mm
Current collector	$\pm 5$ mm working stroke, $\pm 2.5$ mm lateral

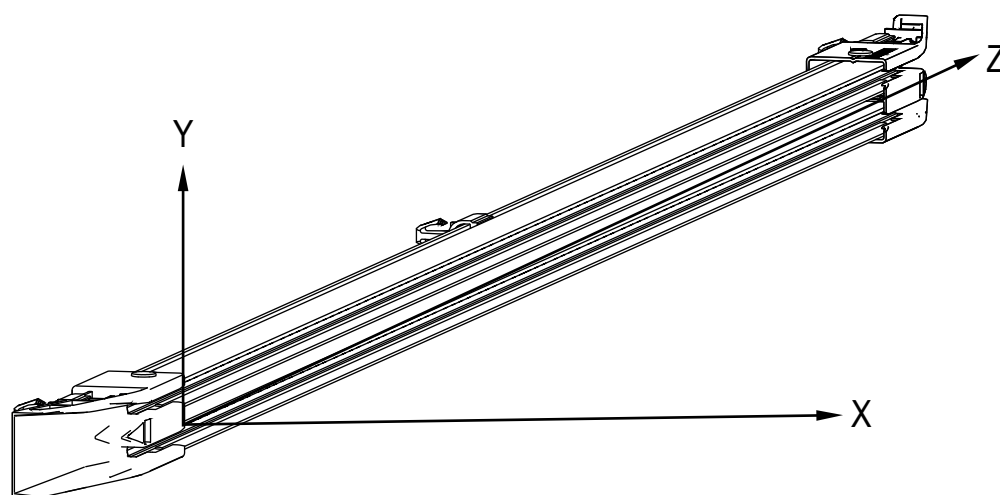

Fig. 3: Conductor Rail 0865 coordinate system



### 3.3 Operating conditions

Specification	Value	Notes
Temperature range	- 5 °C to + 60 °C	In temperatures of 0 °C and below, the max. relative humidity must not exceed 30%.
Max. Relative humidity	85 %	
Max. operating temperature difference	40 K	
Installation situation/environment	Dry indoor area	See Section 3.3.1
Protection class	IP2X	
Altitude above sea level	≤ 1000 m	Above mean sea level (DIN EN 60204-1).

#### 3.3.1 Unsuitable ambient conditions

The conductor rail is not suitable for and **must not be installed** or **operated** under the following environmental conditions:

- In environments containing chemical substances or gases that can potentially permanently damage the conductor rail's materials (corrosion) or drastically deteriorate on the insulation profile.
- In ambient air that contains solvent vapors or aromatic compounds.
- In ambient air that contains flammable or explosive gases or dusts.
- In dusty environments.
- Outside closed areas.
- In environments with relative humidity of more than 85%.
- In close proximity to splashing water.
- In environments that require a higher protection class than IP21

## 4 Description and Functional Principle

---

### 4.1 Brief description

The Conductor Rail System ChargeLine 0865 is a system that charges during movement and standstill.

The conductor rail system consists of the following components:

- Hanger clamp
- Conductor rail with one or two pickup guides
- Line feed
- Optional: Connector 0835
- Optional: Conductor Rail 0835

The Conductor Rail System 0865 is similar to the Conductor Rail System 0835. The Conductor Rail 0865 can be connected or combined with conductor rails from the 0835 product range using the Connector 0835. The Conductor Rail System 0865 is designed for indoor use only.

In order for the Conductor Rail 0865 to slide well, the fixing web at the rear side of the pickup guide to be is broken away. As a result, there is always an anchor point at one end and a sliding bearing can be produced at another end.

Using the hanger clamps, the conductor rails are attached to a customer-specific support structure/substructure. All lengths in the catalog are only valid for installation with a support structure/substructure.

The line feed at the top end of the conductor rail is used to supply the rail with electrical energy that the shuttle (or a different kind of mobile consumer) can access with the aid of a current collector.

### 4.2 Description of assemblies

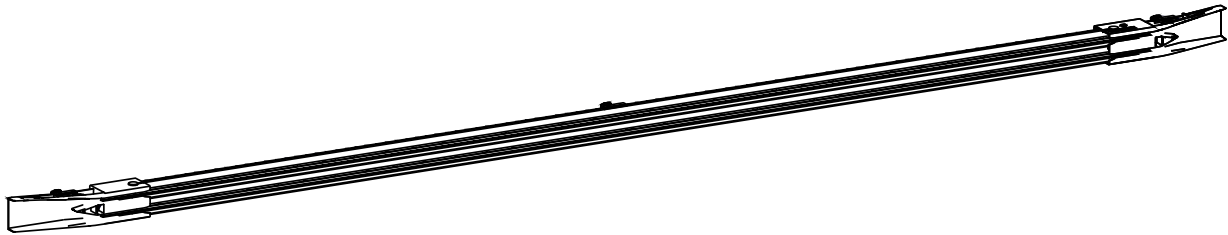

Fig. 4: Conductor rail with pickup guide (both sides)

#### ■ Conductor Rail 0865 with two pickup guides

There are pickup guides on both sides. An infeed and outfeed point is possible on both sides. Connecting cables are also possible on both sides. The length of the connecting cables is configurable (max. 5 m).

Cross-section with double insulated cable: 6 mm<sup>2</sup>/2.5 mm<sup>2</sup>

Cross-section with single insulated cable: 10 mm<sup>2</sup>/6 mm<sup>2</sup>/2.5 mm<sup>2</sup>

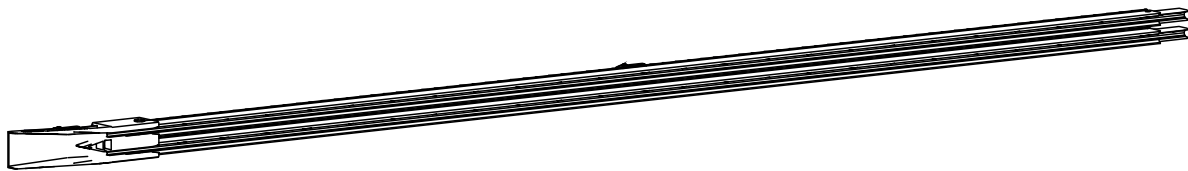

Fig. 5: Conductor rail with pickup guide (one side)

#### ■ Conductor Rail 0865 with pickup guide

There is a pickup guide on one side. A line feed or outfeed point is possible at the pickup guide. The length of the connecting cables is configurable (max. 5 m).

Cross-section with double insulated cable: 6 mm<sup>2</sup>/2.5 mm<sup>2</sup>

Cross-section with single insulated cable: 10 mm<sup>2</sup>/6 mm<sup>2</sup>/2,5 mm<sup>2</sup>

## Conductor Rail System ChargeLine 0865

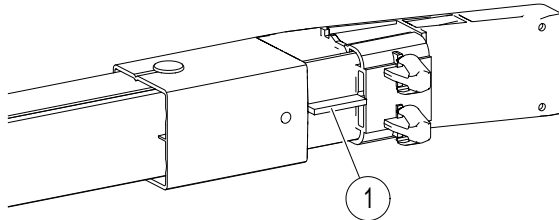

Fig. 6: Anchor Point 0865/sliding bearing

### ■ Anchor Point 0865/sliding bearing

If the fixing web (Pos. 1) is not broken away at the rear of the pickup guide, this functions together with the hanger clamp as an anchor point.

If the web (Pos. 1) is broken away, a sliding bearing is produced so that the conductor rail can expand. The conductor rail thus has a possible air gap of up to 20 mm. This provides sufficient expansion space for systems up to 100 m in length (depending on ambient conditions).

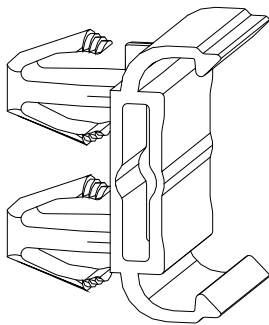

Fig. 7: Hanger Clamp 0865

### ■ Hanger Clamp 0865

The Hanger Clamp 0865 is attached to the customer's support structure with the two clips.

The conductor rails are suspended in Hanger Clamp 0865.

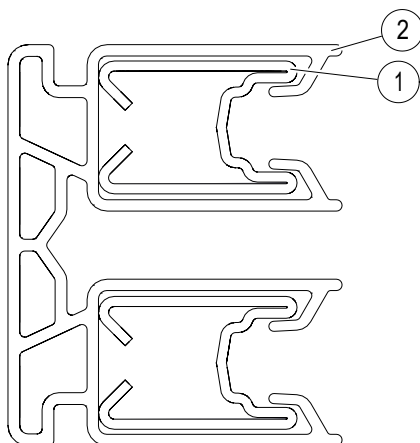

Fig. 8: Conductor Rail 0865

### ■ Conductor Rail 0835

The conductor rail consists of a conductor bar (Pos. 1) and an insulation profile (Pos. 2).

## Conductor Rail System ChargeLine 0865

---

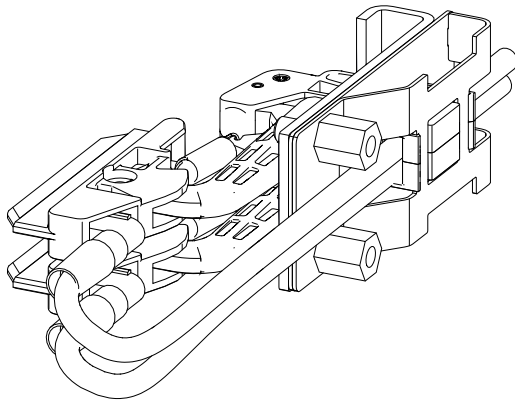

Fig. 9: Current Collector 0865

### ■ Current Collector 0865

The current collector supplies the track-guided mobile consumer with the required energy. It was specially designed for the new Pickup Guide 0865 and includes strain relief as well as cables (always double insulated, cable diameter: 4 mm<sup>2</sup>).

The current collector can optionally include a long cable set.

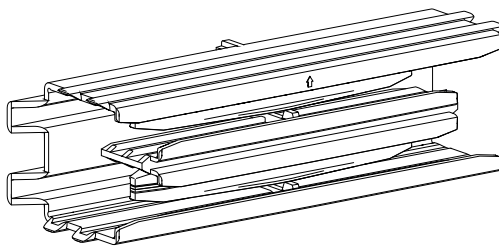

Fig. 10: Connector 0835

### ■ Connector 0835

The Connector 0835 is used to connect the Conductor Rail System 0865 to the Conductor Rail System 0835.

Using a connector reduces the rated current to 32 A.



**DANGER!**

**In a worst case scenario, disassembling the connectors can cause a fire!**

The connectors cannot be removed. Disassembled connectors are defective and can no longer be used because they are deformed during disassembly and their trouble-free function can no longer be guaranteed.

- The connector may only be installed on the level.
- The connectors must be chosen to match the material from which the conductor bars are made, i.e. it must be a connector for a copper conductor bar.
- The connection must not be bent or twisted.

## 5 Transport, Packaging and Storage

---

### 5.1 Transport

#### 5.1.1 Safety information for transport



**DANGER!**

##### **Risk of injury from falling conductor bars when transported incorrectly!**

When being transported on the installation site, there is a risk that the conductor bars may slide out of the insulation profiles if they are not held relatively vertical during transport. Considering the sharp facings, this can cause serious injury and even death if they fall from a great height.

- The conductor rails should be transported as close as possible to the installation site while still inside their packaging.
- The conductor rails must be transported to the installation site by two people and care must be taken that the conductor bars do not slide out of the insulation profiles.
- Do not transport the conductor rails in bundles with a crane.
- Wear protective headgear.

#### 5.1.2 Transporting packaged parts

**Transport packaged parts under the following conditions:**

- Keep dry and free of dust
- Do not expose to aggressive media
- Protect from direct sunlight
- Avoid mechanical vibrations
- Transport temperature: -25 °C to +55 °C
- Relative humidity : 85 %

### 5.2 Storage of packaged parts



**ATTENTION!**

In some cases, there may be instructions for storage on the packaged parts that go beyond the requirements listed here. Comply with them accordingly.

**Store packaged parts under the following conditions:**

- Do not store outdoors
- Store in a dry, dust-free area
- Do not expose to aggressive media
- Protect from direct sunlight
- Avoid mechanical vibrations
- Storage temperature: -25 °C to +max. 55 °C
- Relative humidity : 85 %
- When storing for more than 3 months, check the general condition of all parts and the packaging at regular intervals. If necessary, refresh or replace the preservative.



### ATTENTION!

If stored within this temperature range, stacking the conductor rails on top of each other can cause the plastic insulation to deform!  
→Unpack the conductor rails.



### 6 Installation

---

#### 6.1 Safety

##### 6.1.1 Personnel

- The system must only be installed by specialist personnel!
- The system must be installed by at least 2 persons.

Required protective equipment:



##### 6.1.2 Safety information



**WARNING!**

##### **Risk of injury due to improper installation!**

Improper installation and commissioning can result in serious personal injury and/or material damage.

- Handle open, sharp-edged components carefully.
- Install components properly. Comply with the specified screw tightening torques.
- Secure components so they cannot fall or topple.

Required protective equipment:



**DANGER!**

##### **Risk of injury due to crushing and impacts!**

There is a risk of crushing of skin and limbs due to:

- Current collector (spring force) during installation, disassembly and maintenance.
- Falling conductor rail system components, if they have not been properly installed or if operated under inappropriate operating conditions (e.g., environment that contains solvents).

#### Required protective equipment:



**DANGER!**

#### **Risk of injury due to cutting and severing!**

The ends of the conductor bars can have sharp edges, particularly if they were cut to size at the installation site and have not been deburred.

- Wear protective gloves and protective footwear.
- Carefully deburr the insulation profile and conductor bars after sawing.
- During disassembly: Sawed through, disassembled conductor rails must be handled carefully and properly stored (container or transport box).
- Watch for sharp edges near the installation surface and avoid contact.

#### Required protective equipment:



**CAUTION!**

#### **Risk of puncture wounds and cuts!**

The packaging material can contain sharp objects such as nails and wood splinters that can cause injury to limbs.

- Wear protective gloves
- Wear protective footwear

#### Electrical hazards



**DANGER!**

#### **Risk of death due to electric shock!**

Contact with energized components can lead to death or severe injury due to electric shock. There is also a risk of injury from shock reactions, falling or being thrown across the room as a result of an electric shock.



**DANGER!**

#### **Risk of injury from falling or being thrown across the room after an electric shock!**

Contact with energized components can lead to death or severe injury due to electric shock. There is also a risk of injury from shock reactions, falling or being thrown across the room as a result of an electric shock.



**CAUTION!**

#### **Before working on these components!**

- **Switch off the conductor rail system** according to the 5 Safety Rules (see Section 2.5) and **secure it against being switched on again.**



**CAUTION!**

#### **Before switching the system on!**

- Each time before the equipment or system is started, measure the insulation resistance according to locally applicable technical standards, directives and legal regulations.
- Carry out locally required electrical tests.

## Conductor Rail System ChargeLine 0865

### 6.2 Procedure

#### 6.2.1 System overview

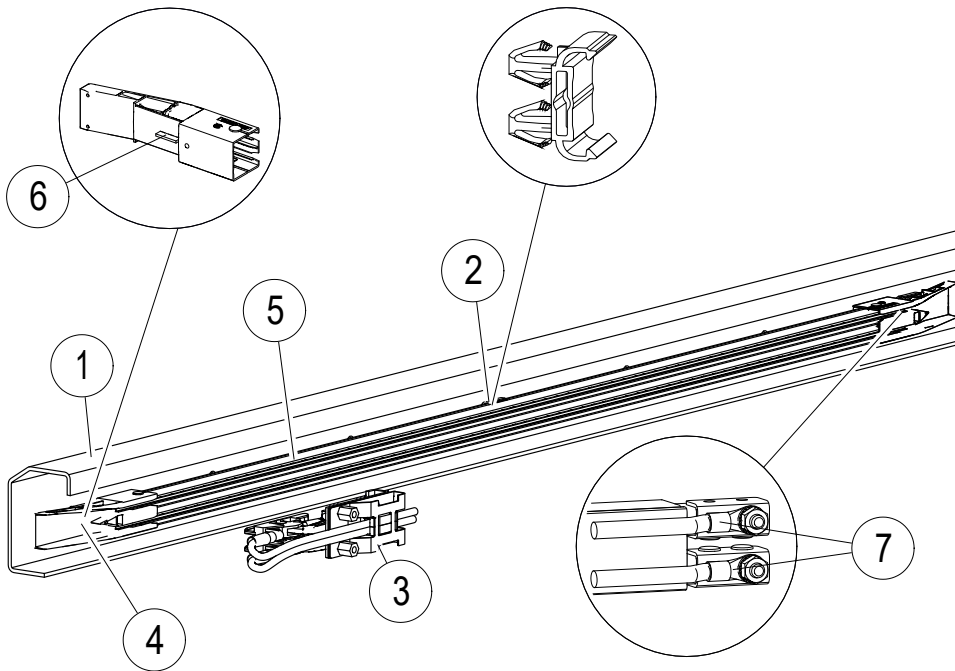

Fig. 11: 0865 system overview

Pos.	Name
1	Customer-side support structure/substructure
2	Hanger clamp
3	Current collector
4	Pickup guide
5	Conductor rail
6	Fixing web on pickup guide
7	Line feed/Outfeed

## Conductor Rail System

### ChargeLine 0865

#### 6.2.2 Required tools

- Crimping pliers for crimping the cable lug
- Cable stripper
- Plastic hammer
- Mounting Kit 0835
- Screw clamp
- File
- Drill  $\varnothing$  9 mm
- Drill  $\varnothing$  3.6 mm
- Saw with fine blade

#### 6.2.3 Structural specifications for installing the system

Item	Specification/comment	
Fixing web (anchor point/expansion joint)	The pickup guide with the fixing web may only be located on one side of the system. At the other end, the fixing web must be removed.	
Distances between the hanger clamps	From pickup guide to the first hanger clamp	max. 200 mm
	Between the hanger clamps	800 mm
Connector	<ul style="list-style-type: none"> <li>■ Once fitted, connectors and connector caps cannot be removed again! This is why the connectors must always be carefully aligned first before they are fitted. If they need to be changed, please contact Conductix-Wampfler before doing so. See Section 6.2.4</li> </ul> →When using <b>copper</b> conductor bars, use copper-plated connectors.	
Connector caps	<ul style="list-style-type: none"> <li>■ The connector caps must be supported by the installation surface in order to be able to withstand the contact pressure of the current collector.</li> <li>■ The backs of the connector caps must be level with the hanger clamps.</li> <li>■ Connector caps must be installed before mounting the connector pins and cannot be pushed on after the installation.</li> </ul>	
Installation surface	The installation surface must be level. The area around the back of the conductor rail must not have any elements that protrude (e.g. screw heads).	
Insulation	The conductor rails must not come in direct contact with electrically conductive materials. Exception back/back guides.	
Min. rail segment length	Dependent on the configured length (shortest rail is 250 mm).	

## Conductor Rail System

### ChargeLine 0865

#### 6.2.4 Installing the conductor rail

##### 6.2.4.1 Installing anchor points

**Work steps:**

- Together with a hanger clamp (Pos. 2), the fixing web (Pos. 3) of the pickup guide (Pos. 1) can be used as an anchor point (see Fig. 12). Hang the conductor rail (Pos. 4) in the hanger clamps (see Fig. 28), so that an anchor point is created and the conductor rail cannot expand.

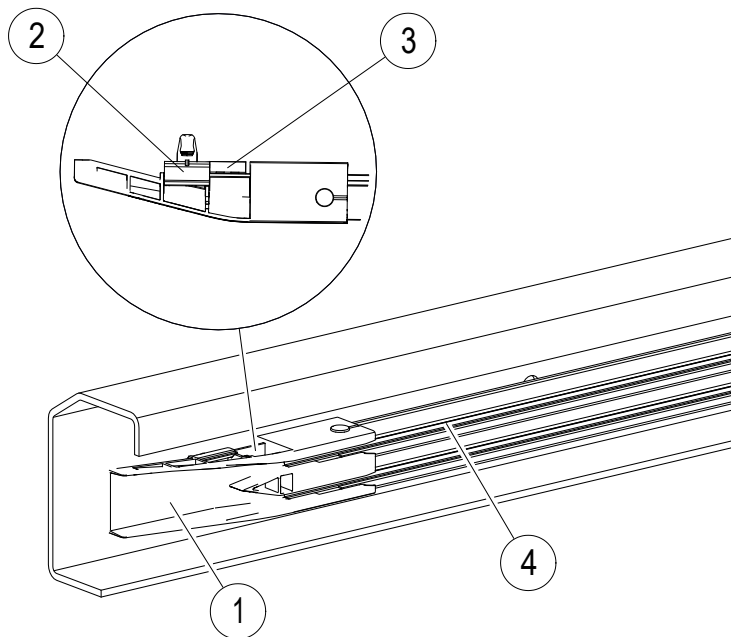

Fig. 12: Conductor rail (Pos. 4) cannot expand

Pos.	Name
1	Pickup guide
2	Hanger clamp
3	Fixing web
4	Conductor rail

## Conductor Rail System

### ChargeLine 0865

#### 6.2.4.2 Installing the expansion joint

- Because the individual conductor bars are combined in one component, the entire conductor rail expands together.
- The connector caps are firmly connected to the conductor bars and move in line with the expansion of the conductor bars.
- The fixing web on the pickup guide, together with the hanger clamp, is the anchor point of the conductor rail. Only one fixing web may be installed per conductor rail.
- The use of expansion units must be carried out in compliance with the max. system length; the permissible temperature range and the installation specifications are not provided.
- The conductor rail system expands along the length of the fixing web (approx. 16 mm). This provides sufficient expansion for systems up to a length of 100 m (depending on environmental conditions and technical parameters).

The maximum permitted length of a Conductor Rail 0865 (+ extension with Conductor Rail 0835) depends on the support structure/substructure and the given temperature. The permitted length can be found in the following table:

$\Delta T$ in Kelvin	Intermediate distance a	Installed on steel	Installed on aluminium
10 K	96 m	100 m	100 m
20 K	48 m	100 m	100 m
30 K	32 m	100 m	80 m
40 K	24 m	80 m	60 m
50 K	20 m	65 m	48 m

#### Work steps:

- Break the fixing web (Pos. 1) away at the rear of the pickup guide and hook the conductor rail into the hanger clamps. This creates an expansion space of  $20 \text{ mm} \pm 9 \text{ mm}$ , so that the rail can slide back and forth in the hanger clamp without any problems. The expansion joint provides sufficient expansion for systems up to a system length of 100 m (depending on the ambient conditions).

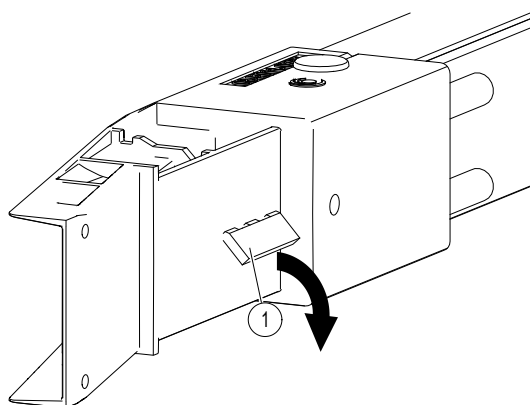

Fig. 13: Break away fixing web (Pos. 1)

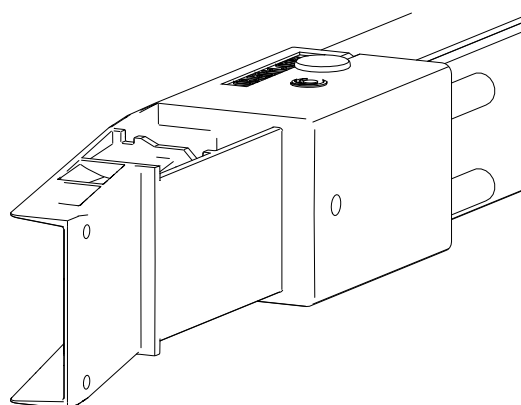
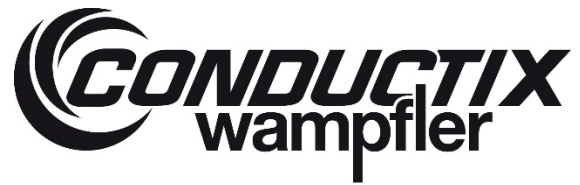

Fig. 14: Expansion joint has been produced without a fixing web

# Operating Instructions



## Conductor Rail System ChargeLine 0865

### Determine the position of the hanger clamp from the expansion joint:

The position of the hanger clamp of the expansion joint should be central.  
The current collector must be de-energized outside the conductor bar.

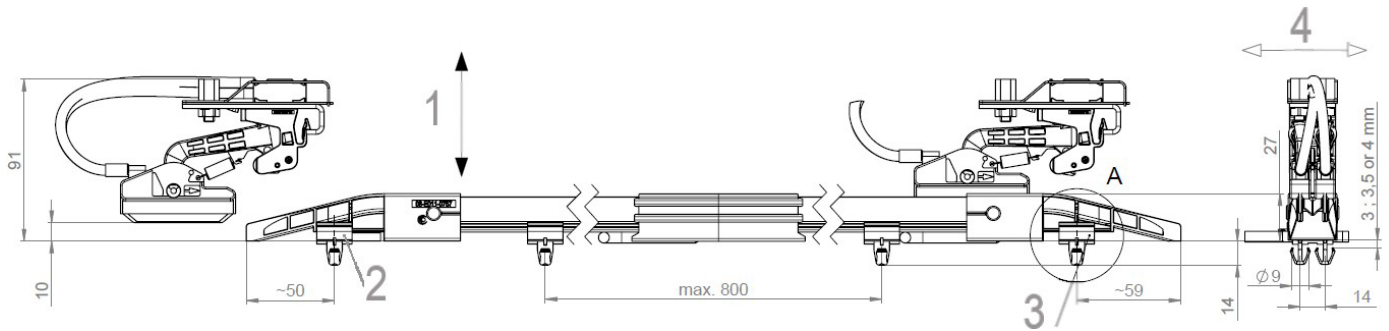

Fig. 15: 0865 arrangement

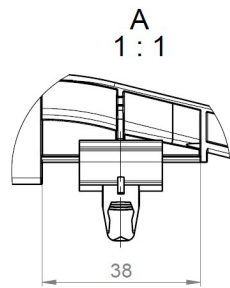

Fig. 16: Sliding bearing

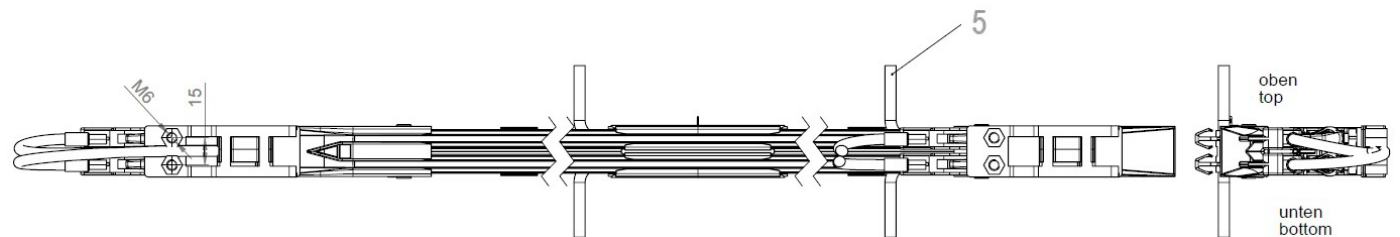

Fig. 17: 0865 arrangement (top view)

Pos.	Name
1	Working stroke $\pm 5$ mm
2	Anchor point
3	Sliding bearing 16 mm
4	Lateral deflection $\pm 3$ mm
5	Cable 6 mm <sup>2</sup> (single insulated)

## Conductor Rail System

### ChargeLine 0865

#### 6.2.5 Installing the line feed

##### Required tools:

- Plastic hammer
- Crimping tool
- Cable stripper

→ Allow the connecting cables that protrude from the line feed end of the conductor rail to be connected to the terminal box by a qualified electrician. Observe local standards and guidelines.

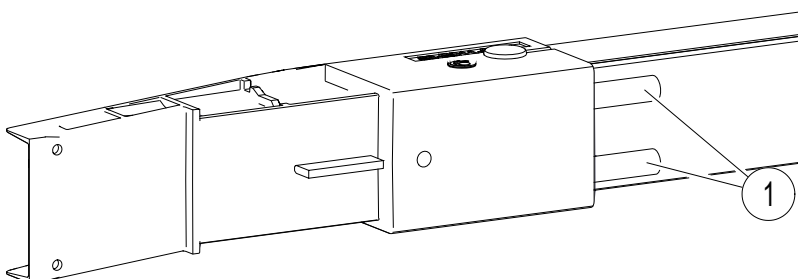

Fig. 18: Conductor Rail System 0865 connection cables

If the pickup guide is yet to be preassembled at the line feed point, the following work steps must be carried out:

- Screw the crimping cable lug onto the bolts (Pos. 2) of the line feed connector (Pos. 1) with spring washer (Pos. 4) and hexagon nut (Pos. 5) (see Fig. 19).
- Strip the connecting cables at the ends and crimp them with the crimping cable lugs (see Fig. 20).
- Slide the pickup guide over the conductor rail end (see Fig. 21).
- Tap the expanding rivet into the hole with a plastic hammer (see Fig. 22).

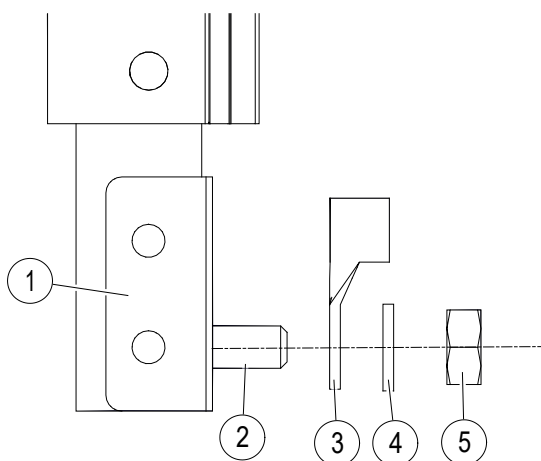

Fig. 19: Screw on crimping cable lug

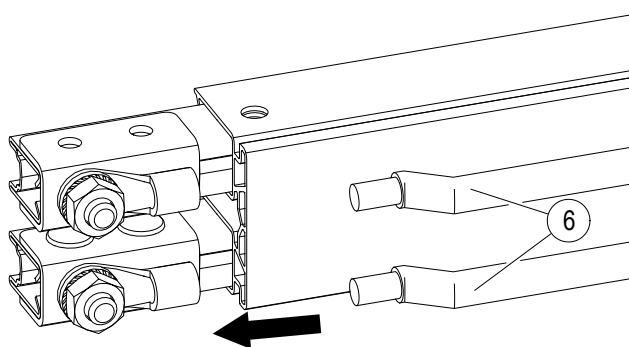

Fig. 20: Crimp connection cables with crimping cable lug



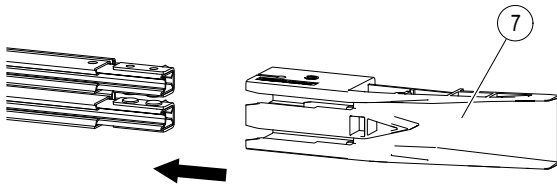

Fig. 21: Slide pickup guide over line feed point

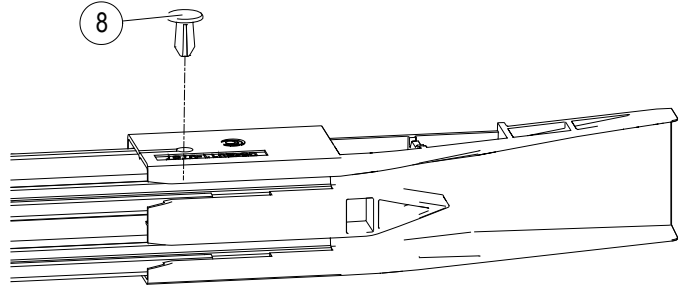

Fig. 22: Tap expanding rivet into hole

## Conductor Rail System

### ChargeLine 0865

#### 6.2.6 Installing the hanger clamps

**Required tools:**

- Drill  $\varnothing$  9 mm

**Work steps:**

→ If there are no holes in the customer's support structure/substructure, these must still be drilled (see Fig. 23).

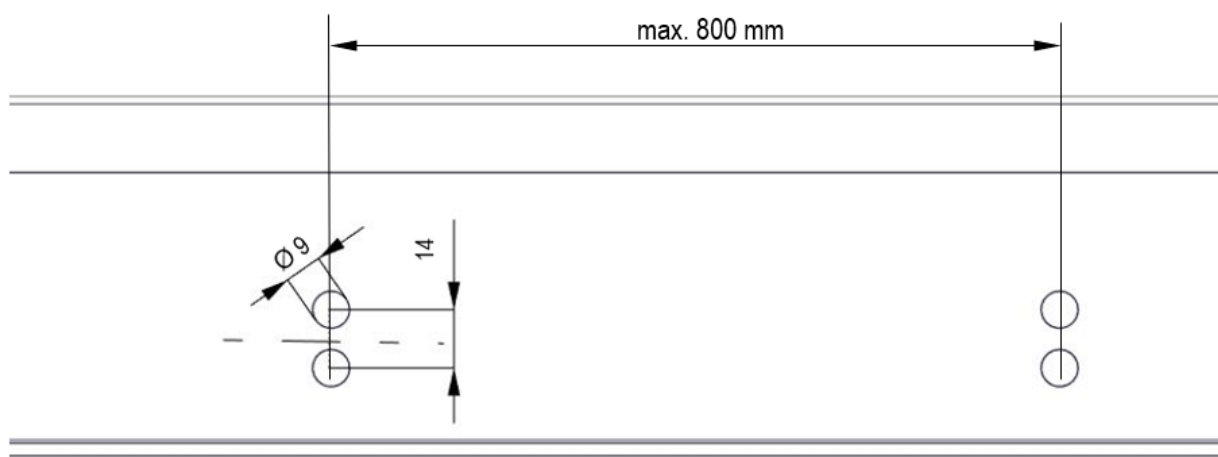

Fig. 23: Drilling pattern for hanger clamp distance

→ Follow the hanger clamp distance dimensions (see Fig. 24).

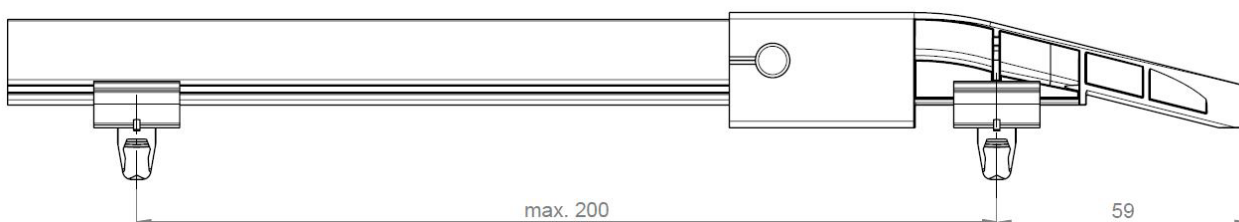

Fig. 24: Pickup guide without fixing web

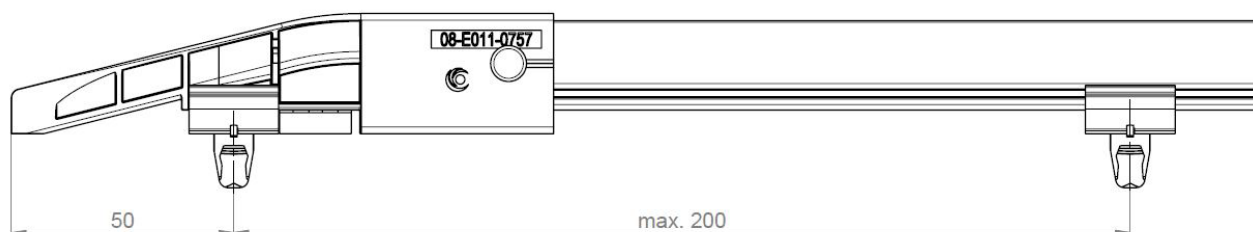

Fig. 25: Pickup guide with fixing web

→ Place the clips (Pos. 1) of the hanger clamp in the hole of the customer-side support structure/substructure (see Fig. 26 and Fig. 27).

## Conductor Rail System ChargeLine 0865

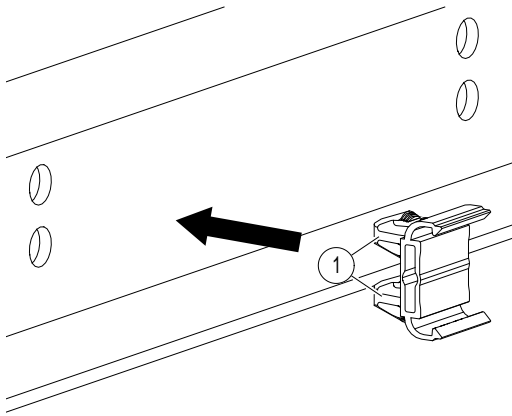

Fig. 26: Insert hanger clamps into customer's support structure/substructure

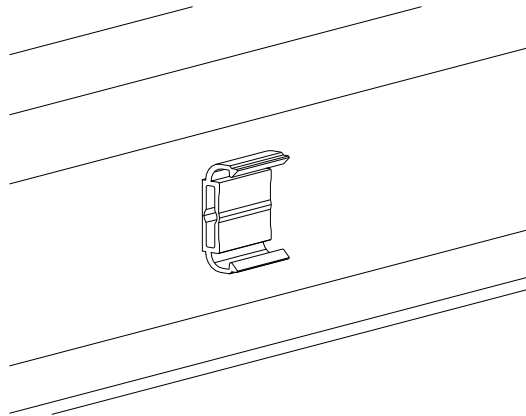

Fig. 27: Hanger clamp is installed on customer's support structure/substructure

→ Hang the Conductor Rail Segment 0865 in the hanger clamp (see Fig. 28).

### 6.2.7 Hang the conductor rail

→ Hook the conductor rail into the hanger clamps (see Fig. 28).

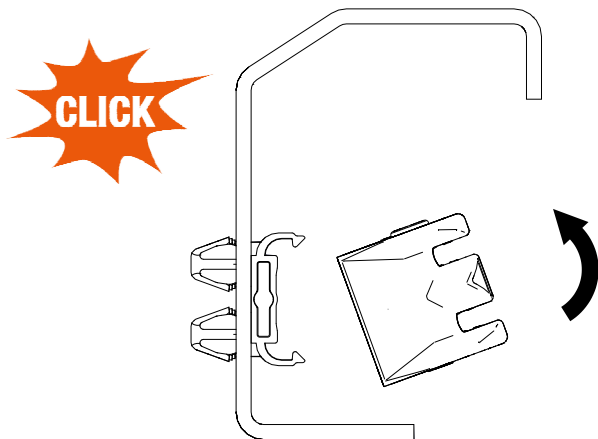

Fig. 28: Hook rail into hanger clamp

### 6.2.8 Adjusting the length



The Conductor Rail 0835 or the Conductor Rail 0865 may be affected by a length adjustment.

See MAL0835-0001 for length adjustment of Conductor Rail 0835.



#### **ATTENTION!**

**Only an open Conductor Rail 0865 may be sawn.  
All rail lengths are configured. The sides with pickup guides and line feeds must not be adjusted!**

### 6.2.9 Connect Conductor Rail System 0835



The Conductor Rail 0865 can be connected to the Conductor Rail 0835.

See MAL0835-0001 for connection to Conductor Rail 0835.

### 6.2.10 Installing the current collector

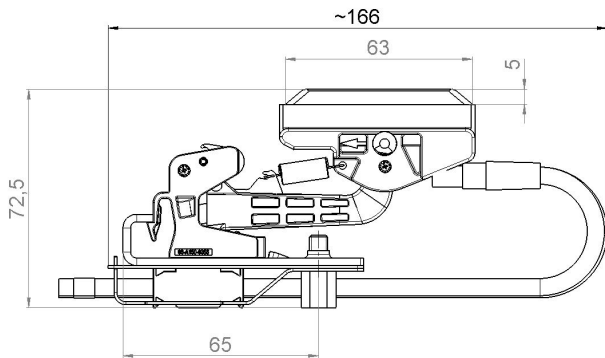

Fig. 29: Current collector dimensions (from the side)

#### Current collector with connecting cable:

Cross-section 4 mm<sup>2</sup>

Always double insulated

Line length is configurable

2-pole unit PH and PE version

The current collector poles on the towing plate of the current collector can be assigned as required.

## 7 Commissioning

---



### CAUTION!

#### Before switching the system on!

- Each time before the equipment or system is started, measure the insulation resistance according to locally applicable technical standards, directives and legal regulations.
- Carry out locally required electrical tests.

1. Each time before the equipment or system is started, measure the insulation resistance according to locally applicable technical standards, directives and legal regulations.
2. Carry out locally required electrical tests.

→ Move a loose current collector over every pole of the conductor rail system and check for freedom of motion.

→ The current collector must not stick and must slide in the rail without hindrance.



### ATTENTION!

The current collectors must not become caught or stick or scrape.  
Repair any faults where necessary.

3. Allow the conductor rail to run for a full cycle in automatic mode (walking speed).



### ATTENTION!

The connecting cables must not pull on, press against or cause the current collectors to twist (see Section Fig. 30 to Fig. 34).

## Conductor Rail System ChargeLine 0865

---

4. Check the current collector's connecting cables.

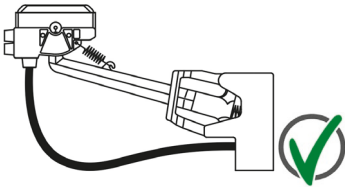

Fig. 30: Connection cable is correctly laid

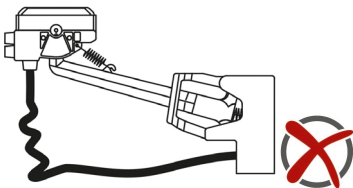

Fig. 31: Do not compress or kink connecting cable

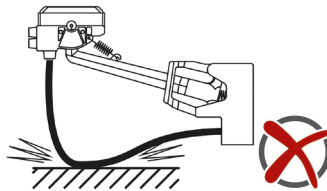

Fig. 32: Connection cable must not rest

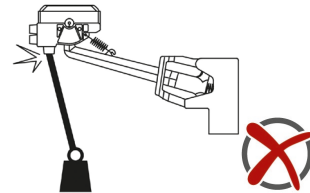

Fig. 33: Do not load connection cable

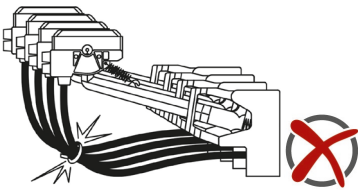

Fig. 34: Do not fix connecting cables with cable ties

### 8 Operation

---

#### 8.1 Safety

In order to follow the **most important safety measures**, the suitable operating conditions specified in Section 3.3.1 and the following sections must be observed.



**DANGER!**

#### **The conductor rail environment may be exposed to electrical current!**

The conductor rail environment may be exposed to electrical current under the following circumstances:

- If the conductor rail is heavily soiled.
- If the conductor rail becomes wet.
- If parts carrying electrical power are open (insulation profile or the insulation of the connection cable are damaged).
- If the hanger clamp or insulation profile fail.
- If the conductor rail falls down and comes into contact with a conductive material.



**DANGER!**

#### **Fire hazard!**

A fire hazard is caused by:

- Overloading the line
- Arc, short circuit or spark formation

- Always comply with permissible current values.
- Comply with tolerances during installation.
- Install electrical fuses according to specifications.
- Do not store easily ignited materials in the vicinity of conductor rails.
- Check, service and clean conductor rails regularly and in accordance with specifications. See Section 12.3



### 9 Maintenance and Service

---

#### 9.1 Safety

Requirements:



Required protective equipment:



**WARNING!**

**Risk of injury due to improperly performed maintenance work!**

Improper maintenance can result in serious injury to persons or material damage. Loosely stacked or scattered components and tools that are left lying around are a source of danger. They are a tripping hazard and improperly stored components can topple or fall to the ground.

### 9.2 Tools and materials

The maintenance work on the conductor rail must be performed using commercially available metric tools.

Maintenance work	Tool
Measure height of sliding contacts	Calipers
Determine contact pressure of sliding contacts	Spring scale with a measuring range of 0 to 20 N

### 9.3 Cleaning

See document WV0800-0001, Cleaning Conductor Rails.

### 9.4 Maintenance plan

The following work is categorized as Service:

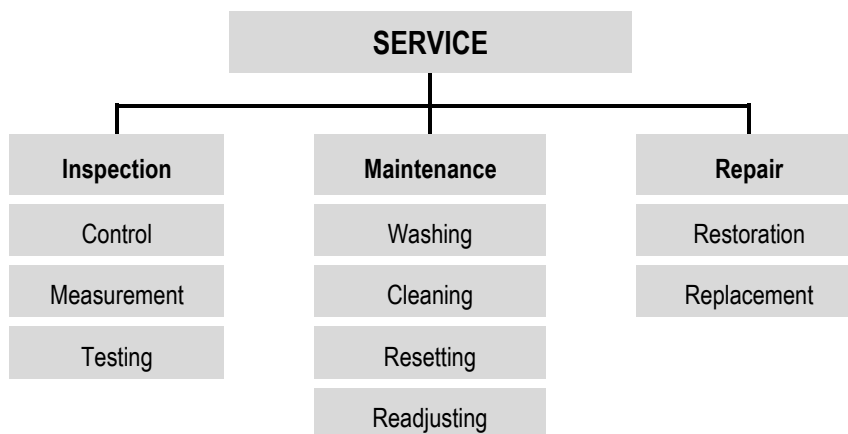

The following sections describe the service work required for optimal, trouble-free operation. The work carried out according to the maintenance plan must be logged.

If regular inspections reveal increased wear, the corresponding servicing intervals should be shortened in accordance with the actual signs of wear.

Contact the manufacturer in case of any questions regarding Service work and intervals – see the customer service address on the last page.

The operator must organize the following maintenance measures on their own in order to preserve the warranty and for general prevention of damage.

- Inspection, maintenance and repair work must only be carried out by trained, qualified technicians!
- Inspection, maintenance and repair measures must always be documented!

## Conductor Rail System ChargeLine 0865

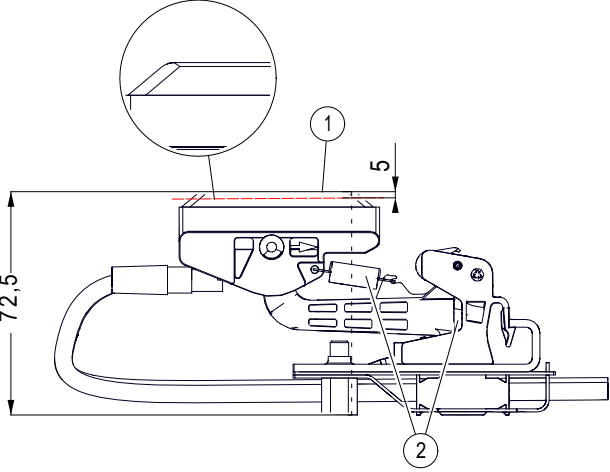
Interval	Service work	To be performed by						
Daily	Visual inspection ■ Are coarse dirt or objects in the conductor rail?	Operator						
4 weeks after commissioning  Afterward: <b>Every 3 months</b>	<p><b>Visual inspection:</b></p> <ul style="list-style-type: none"> <li>■ Check if sliding contacts are worn in the contact area. → Replace the current collector if the wear limit of 1 mm (sliding contact insulation to sliding contact) is reached or exceeded.</li> </ul>  <p><i>Fig. 35: Sliding contact wear limits</i></p> <table border="1" data-bbox="395 1272 1034 1391"> <thead> <tr> <th>Pos.</th> <th>Name</th> </tr> </thead> <tbody> <tr> <td>1</td> <td>Contact surface of the conductor rail</td> </tr> <tr> <td>2</td> <td>Spring</td> </tr> </tbody> </table> <ul style="list-style-type: none"> <li>■ Check sliding contact insulation for cracks and scraping. → Replace the current collector if the insulation is damaged and the sliding contacts are visible, or the sliding contact insulation has cracks.</li> <li>■ Check the insulation for wear, soiling and burn marks. → If necessary, clean insulation profile or repair defect.</li> <li>■ Ensure that there are no constrictions inside the individual poles of the insulation profile (dust or adherent soiling). → Clean the insulation profile with a vacuum or brush, or replace.</li> <li>■ Ensure that the insulation is not affected by foreign bodies (shavings, fluids, contamination, etc.) (short circuit risk). → Clean or restore components, if it is not possible to fully restore the insulating properties, replace the components.</li> </ul>	Pos.	Name	1	Contact surface of the conductor rail	2	Spring	Specialist technician
Pos.	Name							
1	Contact surface of the conductor rail							
2	Spring							

**Functional test:**

- Ensure correct contact pressure.
  - Check for the presence of springs.
  - Check the correct installation height of the current collector 72.5 (see Fig. 35).
  - Adjust the fastening position in the event of deviation.
  - The required contact pressure is ensured by the correct fastening position of the current collector. However, if a measurement of the contact pressure is required, this can be carried out, e.g., with a spring balance.
- Check the freedom of motion of each individual current collector arm.
  - If necessary, clean or replace entire current collector.
- Check the vertical and lateral tolerance of the current collectors relative to the conductor rail.
  - If necessary, correct the mounting position.
  - If necessary, clean insulation profile or repair defects.

Specialist  
technician

## 10 Troubleshooting Table

Requirements:



Required protective equipment:



Fault observed	Source	Cause
Sliding contacts are unevenly worn.	The current collector head's range of movement is restricted.	Only use original Conductix-Wamplfer current collectors, check cable position (ensure that cables can move freely).
	Contact pressure is too high or low.	Install current collector as specified in Fig. 29; use highly flexible Class 6 connecting cables (in accordance with ICE 602228).
Sliding contact insulation is worn away on the side down to the sliding contact.	Check the lateral position of the current collector in the conductor rail. Check alignment with respect to parallelism to the conductor rail, sliding contact must be centrally aligned to the contact surface.	Replace current collector heads; adjust the current collector to the correct height (see Fig. 29).
Sliding contacts wear out too fast.	Sharp edges on the line feed clamp, conductor rails, connections between the conductor rails.	Smooth out sharp edges with a file, compressed air grinder or sand paper.
	Conductor rails dirty or burnt in places.	Check current values; clean rails as specified in maintenance instruction WV0800-0001; replace conductor rails, if necessary.
	Contact pressure too high.	Install current collector as specified in Fig. 29.
The power supply is not continuous, contact is disrupted.	Line feed not professionally connected.	Tighten all screws to the specified torque, see 6.2.4; If necessary, newly crimp and install crimping cable lugs again, see 6.2.4.

# Operating Instructions

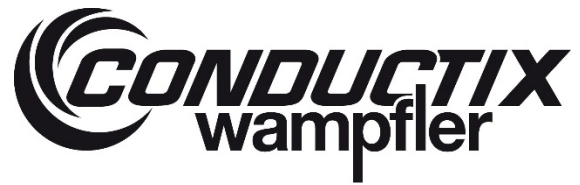

## Conductor Rail System ChargeLine 0865

Fault observed	Source	Cause
	Current collector not properly connected.	Install current collector as specified in Fig. 29; correct connecting cable, replace if necessary.
	Contact pressure too low.	Install current collector as specified in Fig. 29.
	Collision with system components.	Check the system, fasten the affected components in such a way that they cannot be collided with, replace damaged components.
	Abrasive dust has collected at one of the more frequently used transfer points (where the direction of travel is reversed).	Adjust the consumer's movement profile. Move over the end position to push the collected abrasive dust out of the conductor bars.
Insulation profile does not snap into the hanger clamp.	Conductor rail has not been properly installed.	Hang the insulation profile, check components, replace if necessary.
	Use of damaged components.	Replace damaged components.

## 11 Disassembly and Disposal

---

### 11.1 Safety

Requirements:



Required protective equipment:



Required protective equipment:



**WARNING!**

**Risk of injury due to improper disassembly!**

Stored residual energy, angular components, sharp points and edges on and in the equipment or the required tools can cause injury.

- Handle open, sharp-edged components carefully.
- Disassemble components properly.
- Consult the manufacturer in case of doubt

### 11.2 Disassembly

#### 11.2.1 Required tools

- |   |                  |
|---|------------------|
| ■ Wrench  | SW 7             |
| ■ Flat-head screwdriver                               | 1.2 x 6.5x150 mm |
| ■ Cutting tool (angle grinder with thin cutting disc) |                  |
| ■ Pliers to compress the clips of the hanger clamps   |                  |

#### 11.2.2 Disassembling the conductor rail



#### WARNING!

##### Risk of injury due to improper disassembly!

Stored residual energy, angular components, sharp points and edges on and in the equipment or the required tools can cause injury.

→ Handle open, sharp-edged components carefully.

→ Contact Conductix-Wampfler GmbH in case of ambiguities.

→ Slide (1) and turn (2) the screwdriver between the clip of the hanger clamp and the conductor rail so that the conductor rail can be removed from the hanger clamp.

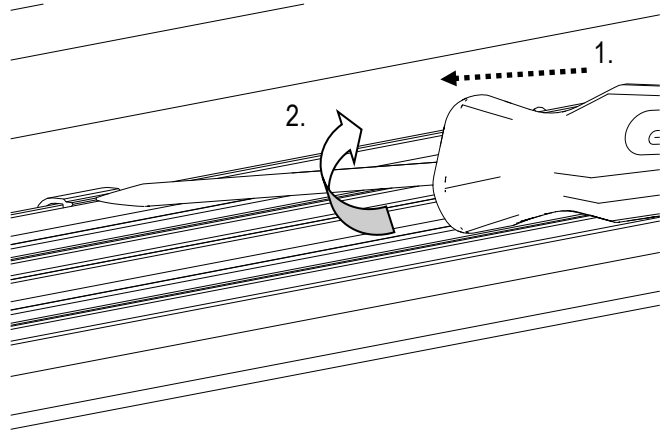

Fig. 36: Disassembling conductor rail



#### CAUTION!

##### Reusing disposable components can create hazards!

Reusing a connector or expanding rivet can create the following hazards:

- The connection is not perfect and reliable.
- Expanding rivet: there is a risk that conductor rails may come loose, wear quickly or be destroyed.
- Connector: high-resistance connection, heating up, fire hazard when easily flammable materials are nearby; decreased performance.

→ Dispose of disassembled connectors and expanding rivets and replace with new ones. These must not be reused!



### 11.3 Disposal

In the absence of return and disposal agreements, recycle the disassembled components:

- Metal components must be sent for recycling.
- Plastic components must be sent for recycling.
- The other components are to be disposed of according to their material composition.



**CAUTION!**

#### **Environmental damage due to improper disposal!**

Electrical scrap, electronic components, lubricants and other auxiliary materials are hazardous waste and may only be disposed of by authorized specialist companies!

The local authority or special disposal companies will provide information on environmentally responsible disposal.

### 12 Additional Documents

---

#### 12.1 Declaration of Conformity

The Declaration of Conformity for this product can be obtained from Conductix-Wampfler GmbH upon request.

#### 12.2 Replacement parts list

The replacement parts are listed in the relevant catalogs.

#### 12.3 Applicable documents

Seq.No.	Document No.	Document Name
1	WV0800-0001	Cleaning Conductor Rails
2	WV0800-0002	Conductor Rail Maintenance Plan
3	MAL0835-0001	Mounting Instructions MultiLine 0835

## 13 Index

---

Applicable documents .....	50	Material defects.....	5
Commissioning.....	38	Operating conditions .....	17
Copyright.....	5	Personnel .....	7
Dangers.....	9	Product description .....	18
Declaration of Conformity.....	50	Replacement parts.....	5
Description of assemblies .....	19	Replacement parts list.....	50
Disassembly.....	47	Safety.....	25, 40, 41, 47
Disposal.....	49	Storage.....	23
Explanation of symbols .....	6	Structural specifications .....	28
Function.....	18	Technical data.....	15
Installation .....	25	Technical support.....	5
Intended use.....	9	Tools .....	28
Limitation of liability .....	4	Transport.....	23
Maintenance and service .....	41	Troubleshooting table.....	45
Maintenance plan .....	42	Unauthorized persons.....	7

**Conductix-Wampfler GmbH**  
Rheinstraße 27 + 33  
79576 Weil am Rhein - Märkt  
Germany

Phone: +49 ( 0) 7621 662-0  
Fax: +49 ( 0) 7621 662-144  
info.de@conductix.com  
www.conductix.com



Importer for the United Kingdom:  
**Conductix-Wampfler Ltd.**  
1, Michigan Avenue  
Salford  
M50 2GY  
United Kingdom

Phone: +44 161 8480161  
Fax: +44 161 8737017  
[info.uk@conductix.com](mailto:info.uk@conductix.com)  
www.conductix.com